



Linde Material Handling

Linde



Order Picker

N20 LoL

Capacity 0.8 t | Series 1115

Practical double order picker

- Long load arms and additional liftable forks allow two pallets to be loaded at a back-friendly height, one after the other, in just one picking cycle
- Fully suspended operating platform provides optimum protection against shocks and vibrations while driving
- Operator's platform in front of the battery ensures maximum maneuverability and a clear view of the warehouse environment
- Robust cast-steel bumper protects chassis and operator's compartment from damage

TECHNICAL DATA (According to VDI 2198)

Characteristics	1.1	Manufacturer		Linde	Linde
	1.2	Model		N20 LoL (without locking pallet)	N20 LoL (with locking pallet)
	1.2.a	Series		1115-00	1115-00
	1.3.	Power Unit		Battery	Battery
	1.4	Operation		Preparation	Preparation
	1.5	Load capacity / Load, main lift only; main lift / initial lift; initial lift only	Q (t)	0.8; 0.8 / 1.2; 2.0 ¹⁾	0.8; 0.8 / 1.2; 2.0 ¹⁾
	1.6	Load centre	c (mm)	600	600
	1.8	Axle centre to fork face	x (mm)	1602 / 1532 ²⁾³⁾	1707 / 1637 ²⁾³⁾
	1.9	Wheelbase	y (mm)	2265 / 2195 ²⁾⁴⁾	2371 / 2301 ²⁾⁴⁾
Weights	2.1	Service weight	(kg)	1473	1473
	2.2	Axle load with load, front/rear	(kg)	1684 / 1865	1684 / 1865
	2.3	Axle load without load, front/rear	(kg)	1182 / 291 ²⁾	1182 / 291 ²⁾
Wheels / Tyres	3.1	Tyres rubber, SE, pneumatic, polyurethane		R + P / P; P + P / P	R + P / P; P + P / P
	3.2	Tyre size, front		ø 254 x 102	ø 254 x 102
	3.3	Tyre size, rear		2x ø 85 x 60 (ø 85 x 85) ⁵⁾	2x ø 85 x 60 (ø 85 x 85) ⁵⁾
	3.4	Additional wheels		2x ø 140 x 50	2x ø 140 x 50
	3.5	Wheels, number front / rear (x = driven)		1x + 1/2 (1x + 1/4) ⁵⁾	1x + 1/2 (1x + 1/4) ⁵⁾
	3.6	Track width, front	b10 (mm)	491	491
	3.7	Track width, rear	b11 (mm)	380	380
Dimensions	4.2	Height of mast, lowered	h1 (mm)	1315 ⁶⁾	1315 ⁶⁾
	4.3	Free lift	h2 (mm)	750 ⁶⁾	750 ⁶⁾
	4.4	Lift	h3 (mm)	750 ⁶⁾	750 ⁶⁾
	4.5	Height of mast, extended	h4 (mm)	1391 ⁶⁾	2228 ⁶⁾
	4.6	Initial lift	h5 (mm)	115	115
	4.8	Height of seat / stand on platform	h7 (mm)	867 / 1000	867 / 1000
	4.10	Height of wheel arms	h8 (mm)	86	86
	4.15	Height at the end of the forks in the lowered position	h13 (mm)	92	92
	4.19	Overall length	l1 (mm)	3968 ⁶⁾	4074 ⁶⁾
	4.20	Length to fork face	l2 (mm)	1567 ⁶⁾	1567 ⁶⁾
	4.21	Overall width	b1 (mm)	800	800
	4.22	Fork dimensions	s / e / l (mm)	55 / 180 / 1200	55 / 180 / 1250
	4.23	Load arm dimensions	s / e / l (mm)	66 / 125 / 2400	66 / 125 / 2500
	4.24	Width of fork carriage	b3 (mm)	780	780
	4.25	Width over forks	b5 (mm)	560	560
	4.26	Internal width of the load arm	b4 (mm)	255	255
	4.31	Ground clearance, below mast	m1 (mm)	20 / 145 ²⁾	20 / 145 ²⁾
	4.32	Ground clearance, centre of wheelbase	m2 (mm)	20 / 145 ²⁾	20 / 145 ²⁾
	4.33	Load dimensions b12 x l6	b12 x l6 (mm)	800 x 1200 lengthwise	800 x 1200 lengthwise
	4.34	Aisle width with predetermined load dimensions	Ast (mm)	4262 / 4253 ⁴⁾⁷⁾	4275 / 4264 ⁴⁾⁷⁾
4.34.1	Aisle width with pallet 1000 x 1200 across forks	Ast (mm)	4367 / 4352 ⁴⁾⁷⁾	4392 / 4374 ⁴⁾⁷⁾	
4.34.2	Aisle width with pallet 800 x 1200 across forks	Ast (mm)	4089 / 4058 ⁴⁾⁷⁾	4143 / 4104 ⁴⁾⁷⁾	
4.35	Turning radius	Wa (mm)	3169 / 3097 ⁴⁾	3275 / 3203 ⁴⁾	
Performance	5.1	Travel speed, with / without load	(km / h)	10 / 12	10 / 12
	5.1.1	Travel speed, backward, with / without load	(km / h)	10	10
	5.2	Lifting speed, initial lift, with / without load	(m / s)	0.06 / 0.07 ⁶⁾	0.06 / 0.07 ⁶⁾
		Lifting speed, main lift, with / without load	(m / s)	0.12 / 0.2 ⁶⁾	0.12 / 0.2 ⁶⁾
	5.3	Lowering speed, initial lift, with / without load	(m / s)	0.06 / 0.08 ⁶⁾	0.06 / 0.08 ⁶⁾
		Lowering speed, main lift, with / without load	(m / s)	0.3 / 0.2 ⁶⁾	0.3 / 0.2 ⁶⁾
	5.8	Climbing ability, with / without load	(%)	13 / 20	13 / 20
	5.9	Acceleration time (10 m), with / without load	(s)	6.1 / 4.9	6.1 / 4.9
5.10	Service brake		Electro-hydraulic	Electro-hydraulic	
Drive	6.1	Drive motor rating S2 60 min	(kW)	3.0	3.0
	6.2	Lift motor rating at S3 10 %	(kW)	2.2	2.2
	6.3	Battery according to DIN 43535 / 36 A / B / C / no		45535 (3 PzS Lateral Change)	45535 (3 PzS Lateral Change)
	6.4	Battery voltage / capacity (5 h)	(V / Ah)	24 / 375	24 / 375
	6.5	Battery weight (± 10 %)	(kg)	290	290
	6.6	Energy consumption according to VDI cycle normalized	(kWh / h)	0.59	0.59
	6.7	Turnover output according to Vdi cycle	(T / h)	136	136
	6.8	Consumption according to turnover output	(kWh / h)	1.78	1.78
Others	8.1	Type of drive control		LAC	LAC
	10.7	Noise level at operator's ear	(dB(A))	< 85	< 85
	Level of vibration felt by the operator	(m / s ²)	0.7	0.7	

1) Pallet truck capacity on the fork arms, with initial lift option
 2) Low / high position fork arm
 3) Value with a Simplex mast

4) With battery line 6.3 (+ 75 mm for 4 PzS)
 5) Figures in (): Truck equipped with tandem load wheels
 6) Value for a mast 750E, other value see mast tables

7) Ast = Wa + R + a, Safety distance a = 200 mm

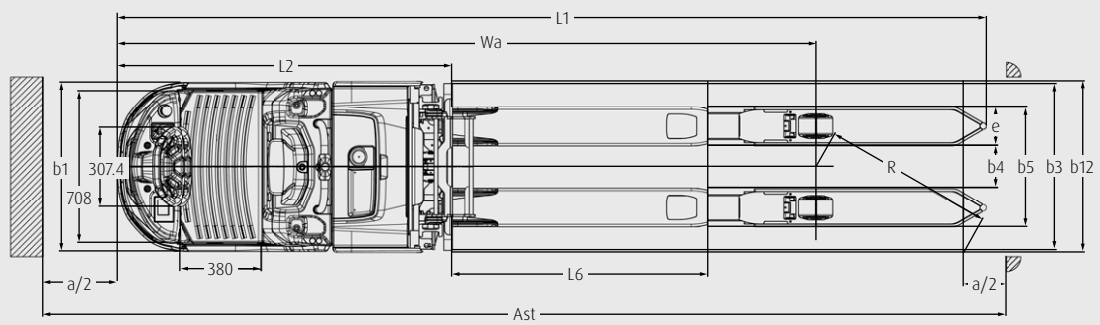
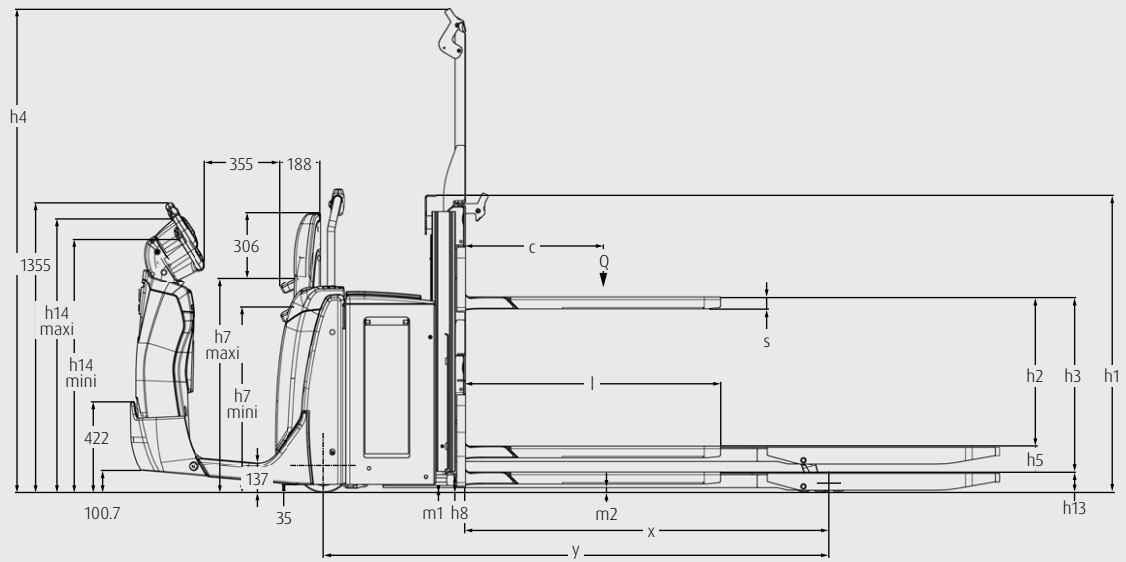

MAST TABLES

SIMPLEX MAST (in mm)

Lift	h3: 750		h3: 912		h3: 1612	
Height measurements	h1: 1315	h2: 750	h1: 1465	h2: 912	h1: 2065	h2: 1545
	h3: 750	h4: 1382	h3: 912	h4: 1465	h3: 1612	h4: 2132
	h5: 115		h5: 115		h5: 115	
Model						
N20 LoL	○		○		○	

○ Optional equipment – Not available

h1: Height of mast, lowered

h2: Free lift

h3: Lift

h4: Height of mast, extended

h5: Initial lift



STANDARD AND OPTIONAL EQUIPMENT

Model/Equipment		N20 LoL
Safety	Front casted steel bumper	●
	Front rubber protection (mounted on the casted steel bumper)	○
	Linde BlueSpot™	○
	Automatic speed reduction when cornering	●
	Front feet protection	○
	Mast stop landing (300 mm)	●
	Key switch	●
	Log in PIN code	○
Service	CAN bus technology	●
Digitalisation	Linde connect	○
	ac: access control PIN	○
	ac: access control RFID	○
	Data transfer Wifi	○
	Data transfer Online	○
	dt: crash detection	○
	an: usage analysis	○
	Bluetooth USB Stick	○
	dt: trouble codes	○
Operation / Load Handling	Inching control (forward only or forward/backward)	○
	Rear initial and mast lift control	●
	Low Speed if initial lift low	●
	Initial lift electrical stop sensor	●
	Soft landing on forks	○
	Mast pressure sensor	●
	Load backrest 1000 mm	○
	Pallet locking system	○
Environment	Cold store -35 °C (in/out)	○
Workplace	Fully suspended operator compartment	●
	Height adjustable Linde Steering Wheel	○
	Knee protection	●
	Multifunction coloured display hour meter, maintenance indication, battery discharge indicator and internal fault code indication	●
	Fixed roundly-shaped backrest	●
	Height adjustable backrest incl. foldable seating support	○
	Front bow	○
	Vertical central pole	○
	Support data terminal and power supply cable 24 V	○
	Support clipboard DIN A4 and support for scanner	○
	Shrink wrap pole and rear bin	○
Rear lower storage	○	
Mast	Mast protection: polycarbonate	●
	Mast protection: mesh	○
Attachment / Forks	Fork carriage: 560 mm	○
	Fork carriage length: 1200 mm or 1250 mm	○
	Load arms length: 2400 mm or 2500 mm	○
	Overhang: 800 mm	○
Axles and Tyres	Drive wheel polyurethane	●
	Drive wheel cushion rubber, non marking and wet grip	○
	Single load wheels polyurethane	●
	Tandem load wheels polyurethane (greasable)	○
	Standard castor wheel	●
Drive and Brake-System	Power assisted steering	●
	3 kW AC motor (maintenance free)	●
	Electromagnetic braking system	●
	Battery compartment, side change 3 PzS (345 Ah/465 Ah), incl. ergonomic lever and metal rollers	●
	Battery compartment, side change 4 PzS (460 Ah/620 Ah), incl. ergonomic lever and metal rollers	○
	Battery compartment, Li-ION battery 4.5 kWh (205 Ah) / 9.0 kWh (410 Ah) incl. side plug for opportunity charging	○
Li-ION 24 V-Charger	○	

● Standard equipment ○ Optional equipment – Not available

CHARACTERISTICS



Linde BlueSpot™ and front LED light

Safety

- Automatic speed reduction in curves and increased braking performance in heavy loads offer maximum safety
- Regulated lowering to the load arms to allow soft landing of the load
- Automatic stop if the vehicle registers an unoccupied driver's platform or the emergency button is activated
- The driver's platform is positioned in front of the battery, giving him an optimum all-round view of the warehouse environment
- Additional options such as front LED and Linde BlueSpot™ maximize safety in the warehouse



Easy-to-use pallet locking

Ergonomics

- Liftable forks place pallet at optimum height, thus reducing physical strain on the operator
- Low access on both sides, 137 mm high, ensures quick boarding and alighting
- For short distances, the operator can conveniently control the vehicle from both sides using the optional pedestrian function.
- Optional pallet locking device ensures safe transport and easy release of the second pallet
- Fully suspended operator's compartment reduces vibrations and shocks transmitted to steering wheel and platform



Intuitive Linde steering wheel

Handling

- 3 kW three-phase AC motor for effective acceleration to a top speed of 12 km/h
- Depending on application requirements lead-acid or optionally lithium-ion batteries are available
- Adjustable Linde Steering wheel provides intuitive operation with meaningful symbols indicating the key vehicle functions
- Electric steering centering with sensors on the ground ensures reliability on transport routes
- Initial lift facilitates transport over ramps and uneven surfaces



Front casted steel bumper

Service

- Up to 1000 operating hours without service check
- Maintenance-free three-phase AC technology and adjustment-free brakes reduce service costs
- Engine and battery cover can be easily opened for access to the technical compartment
- Essential vehicle parameters can be read out via CAN bus connection via laptop
- Robust cast-steel bumper protects vehicle frame and operating platform to reduce collision damage

Subject to modification in the interest of progress. Illustrations and technical details could include options and not binding for actual constructions. All dimensions subject to usual tolerances.

Presented by:

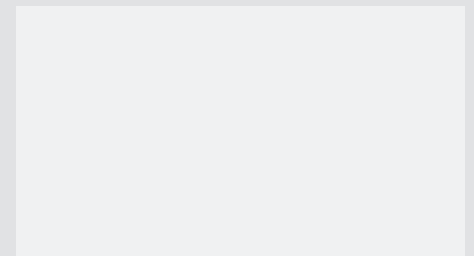

Linde Material Handling GmbH
Carl-von-Linde-Platz | 63743 Aschaffenburg | Germany
Phone + 49 6021 99 0 | Fax + 49 6021 99 1570
www.linde-mh.com | info@linde-mh.com

Printed in Germany | 093.e.0,5.0819.lndA.Ki